



RKS ROAD KING SLOPER®

**THIS IS PRODUCTIVITY!
KEEP YOUR GRADER OUT OF THE DITCH.**

DOUBLE GRADER PRODUCTIVITY with a Rockland Road King Sloper®. Increase travel speed and traction by keeping your grader on the road—out of the ditch. Plus with a Rockland RKS Road King Sloper® you can still articulate your grader.



**THE BOTTOM LINE IS THAT
A ROCKLAND ROAD KING SLOPER WILL
DEFINITELY MAKE DITCHING AND SLOPING
A LOT EASIER!**



DESIGNED TO PRODUCE...

Yes, the Rockland Road King Slopers were designed to produce. When it became obvious that a new generation of slopers was needed for today's modern articulated graders, we started with a clean sheet of paper, committed to creating a more productive sloper. Here are the results:

- A sloper that can be used while the grader is articulated rather than having to lock out articulation and sacrifice this important feature.
- Thirty-two inches of hydraulic sideshift for extra reach to keep the grader on the road, out of the ditch.
- Accurate hydraulic blade control.
- Easy removal from the grader. Pull three pins and pull apart the quick disconnect hose fittings. It doesn't get any easier than this.
- Hydraulic pressure relief rather than old fashioned, hard to replace shear pins.

These new features combine to make the Rockland Road King Sloper the best sloper available anywhere.

BUILT TO LAST...

Rockland Road King Slopers were designed to produce—and built to last! The hydraulics are first class. Only Aeroquip high-pressure hoses and fittings are used. The heavy-duty hydraulic cylinders feature oversize, chrome plated, induction hardened cylinder rods, heavy-duty barrels, and the best seals available. This means years of dependable service. The entire frame, moldboard, and attaching brackets are made from weight-saving, high strength alloy steel. The heavy-duty box frame moldboard is equipped with standard, heat-treated, alloy reversible cutting edges. Road King Slopers have been in production for over thirty years. They have a well deserved reputation for quality and dependability. The latest Rockland Road King Slopers continue that tradition.

THIS IS VERSATILITY...

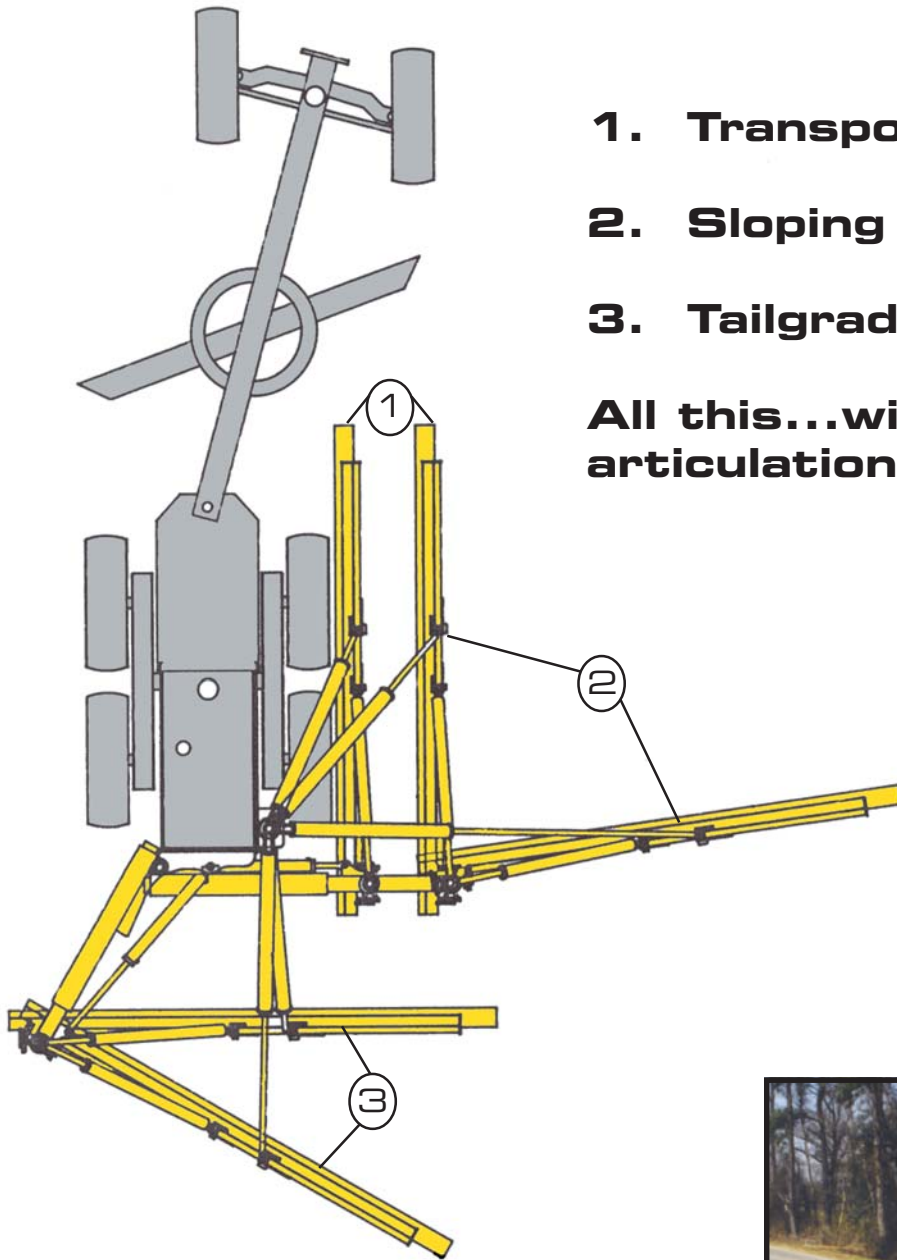

1. Transport Position

2. Sloping and Ditching

3. Tailgrading Option

All this...with full grader articulation!

U.S. Patent No. 5,542,478



SPECIFICATIONS...

HYDRAULICS - Four control valves are required for operation of the sloper. If the sloper has the tailgrading option, two of the four grader control valves must have a float function. If the grader does not have the necessary valves, a four-spool valve is available as an option. Sloper hoses are equipped with quick couplers. Aeroquip high-pressure hose and fittings are standard equipment. Hydraulics are certified for operation to thirty degrees below zero.

HYDRAULIC CYLINDERS - Double-acting, heavy-duty, equipped with induction hardened heat-treated chrome plated rods, and 3000 psi rated barrels.

INSTALLATION - RKS mounting brackets are either bolted or welded to the grader's frame. NOTE: If the grader uses struts with a ripper, OEM struts are required for installation and are not supplied with the sloper.

OVERLOAD PROTECTION - Hydraulic pressure relief in all circuits. If grader control valve is used, the valve's sections must have dual port reliefs and must be adjustable within a range of 900 to 2800 psi. If grader valves are not capable of adjusting the port relief pressures an optional pressure relief kit is available from Rockland.

KEY DIMENSIONS AND WEIGHTS

Widths

Transport position—Add 21" (533mm) to grader width

Tailgrading— 108" (2743mm)

Reach

Sidesloping—19'6" (5944mm) from outside of rear tire to tip of moldboard

Moldboard

Length—16' (4877mm)

Maximum Clearance at Heel—12" (305mm)

Cutting Edge size(2)—½" x 6" x 96" (12.7mm x 152mm x 2438mm)

Height—21" (533mm)

End Bits(2)—½" x 8" x 21" (12.7mm x 203mm x 533mm)

Thickness—355A - 5/16" (7.8mm)

455A - 1/2" (12.7mm)

Standard Unit Weights: 355A - 4650 lbs. (2109 kg)

455A - 5200 lbs. (2359 kg)

Options

Tailgrading—Frame and Wheels: Add 500 lbs. (227 kg)

7' (2134mm) Moldboard Extension: 355A - 512 lbs. (232 kg)

455A - 760 lbs. (345 kg)

(metric)



U.S. Patent No. 5,542,478
Specifications subject to change without notice.

MOUNTING INFORMATION

Rockland Road King Slopers are for graders from 90 to 232 HP. They come complete with necessary mounting hardware and hydraulic hoses. Control of the sloper is by either the grader's auxiliary valves or the optional Rockland control valve.

WARRANTY

Rockland Road King Slopers are guaranteed against failure due to defective design, workmanship, or materials for a period of one year or 2,000 hours.



Distributed by:

ROCKLAND MANUFACTURING CO.
P O BOX 5
BEDFORD, PA 15522
www.rocklandmfg.com